

RELEASÉ

3591598-02 - Heruntergeladen von www.volvo-penta.com 23.02.2008 16:04:06

Drawn	Proj. no.	P/A
B-5944	SE 03	2.9.01
Scale	Unit	Date
		1998

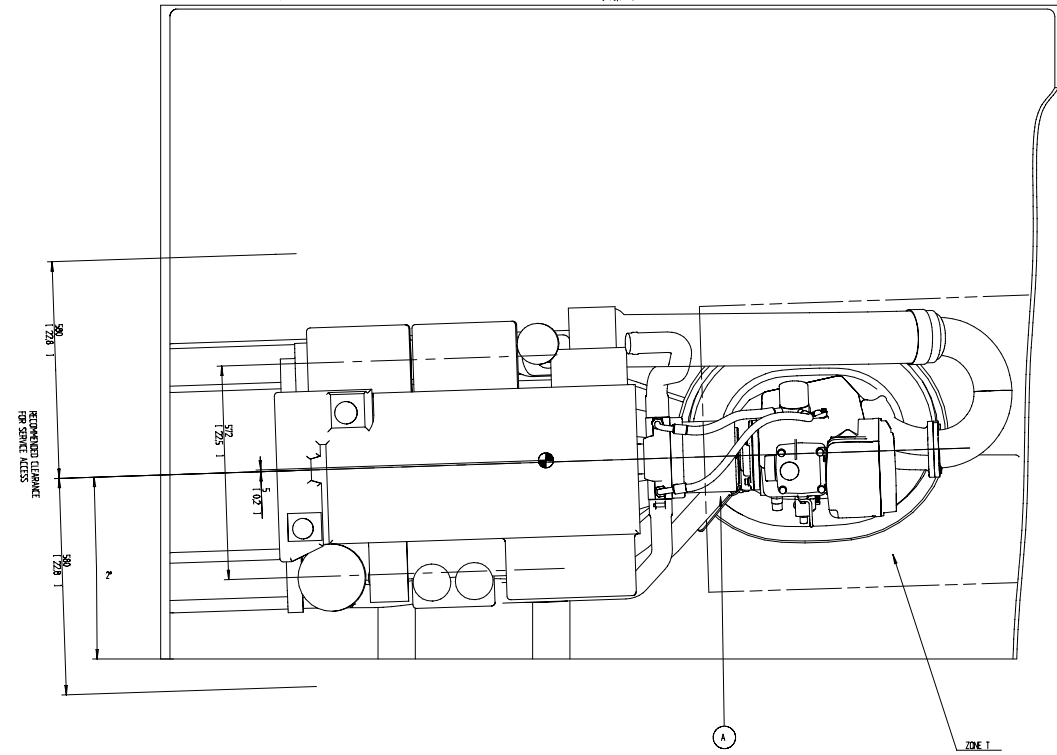
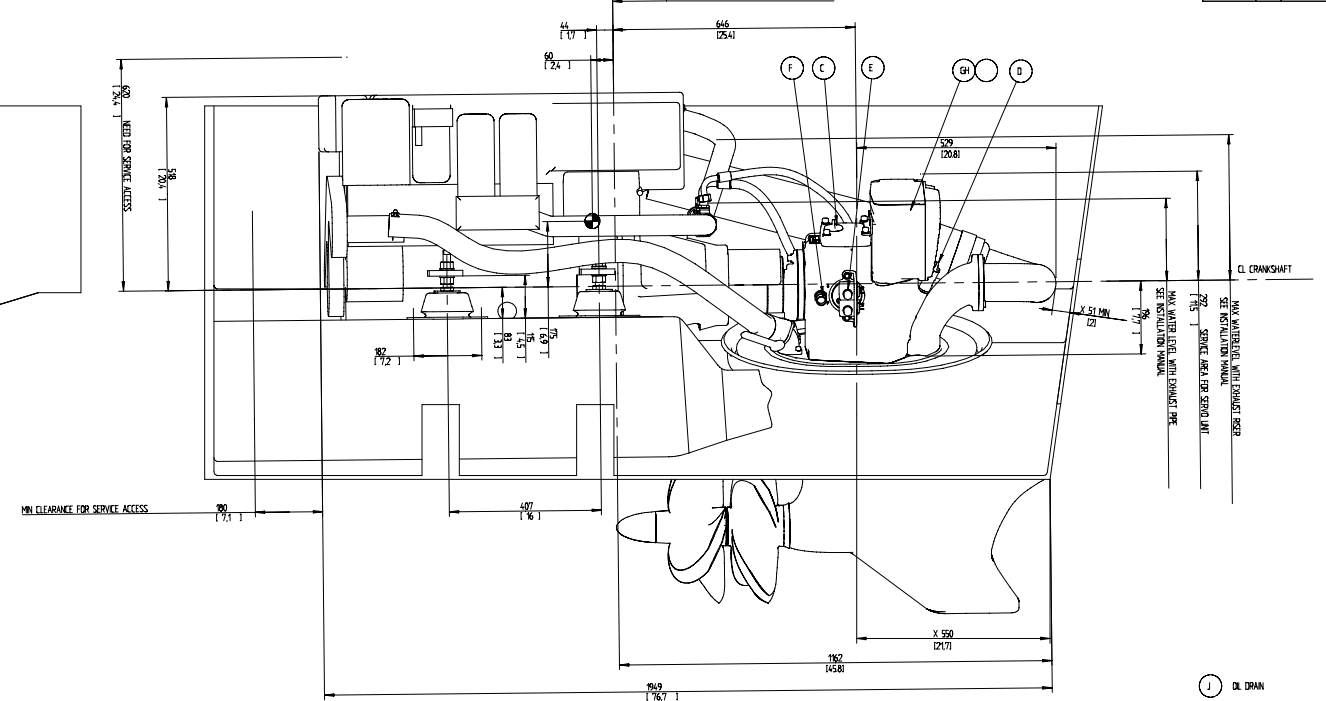
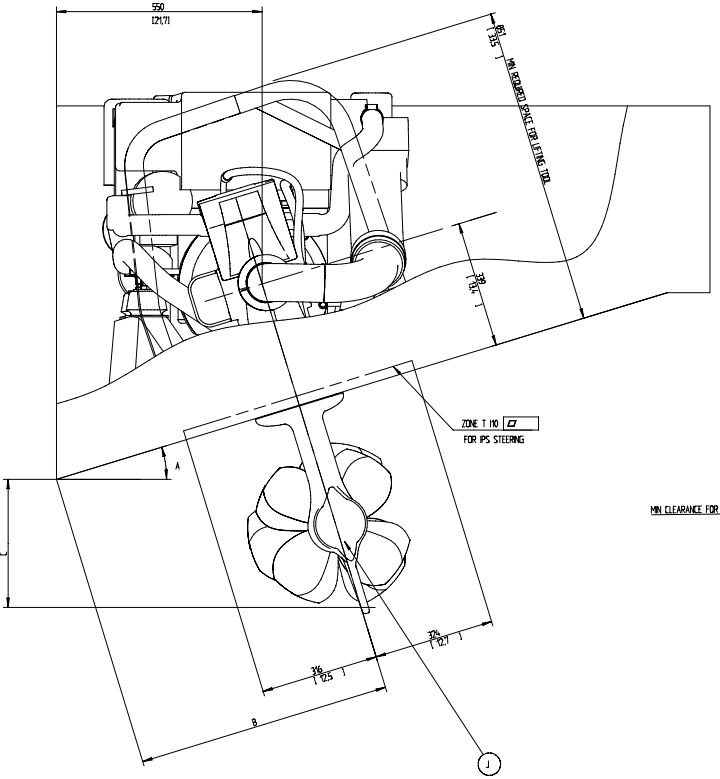

- (J) OIL DRAIN
- (H) CONNECTION ELECTRICAL CONTROL
- (E) CONNECTION BATTERY POS. AND NEG.
- (F) CONNECTION OIL TEMP./PRESSURE
- (E) CONNECTION SHIFT SLEEVES
- (D) OIL DIPSTICK GEAR BOX
- (C) OIL FILLER GEAR BOX
- (A) SEA WATER INLET

⊗ CENTER OF GRAVITY
 BED AND HULL DIMENSIONS SEE DWG. 3591375

ENGINE RELATED ITEMS SEE DWG. 3591349
 WEIGHT ENGINE AND GEARBOX 747 kg (WITHOUT OIL AND WATER)

FOR LAMINATION AND ENGINE BED STRUCTURE,
 PLEASE VIEW INSTALLATION DRAWING FOR PS 400/500/600

A*	B	C
5	582	532
6	589	521
7	596	508
8	603	496
9	611	483
10	618	469
11	626	455
12	635	441
13	643	426
14	652	410
15	661	395
16	670	378
17	679	362
18	689	344
19	699	326
20	709	308
21	720	289
22	731	270
23	742	250
24	753	229

VOLVO
PENTA

3591598

ENGINE INSTALLATION
PS WITH DA

INSTALLATION DRAWING

3591598

02